

# AMERICAN RIFLE COMPANY

## M4 BARLOC<sup>®</sup>

### Installation Procedure for use with shouldered barrels

#### Warning:

Before working on any firearm, point the muzzle in a safe direction and visually and physically inspect its chamber to ensure that it is unloaded.

1. Ensure that the breech end of the barrel is machined in accordance with the illustration below. It is highly recommended to use barrels with shanks at least 1.250" (31.75mm) in diameter.
2. Degrease and clean the barrel tenon, the receiver, and all parts of the Barloc.
3. Apply a thread lubricant (i.e. Anti-Seize) to the barrel tenon.
4. Loosen the screw within the Barloc split collar by about three turns.
5. Install the Barloc assembly over the barrel tenon as illustrated below.
6. Ensure that the conical faces of the washers are directed towards the split collar as illustrated below.
7. Insert the proper GO head-space gage into the chamber of the barrel.
8. Ensure that the bolt is in the closed and locked position within the receiver.
9. Screw the barrel into the receiver until the head-space gage firmly contacts the bolt-face.
10. If using a Barloc with integrated recoil lug, orient the lug as desired.
11. Fully insert the 5/32" (4mm) hex key into the socket of the clamp screw and use the long end of the key as a lever to orient the split collar with the split at the 12 o'clock position.
12. Using a torque wrench, apply 90 lb<sub>f</sub>-in (10 Nm) of torque to tighten the clamp screw. If a torque wrench is not available, use the 5/32" (4mm) hex key to tighten the screw by turning it 1-1/4 turns beyond the point at which resistance to turning was first encountered.
13. Extract the GO-head space gage from the chamber and insert the NO-GO head spaced gage.
14. Attempt to close the bolt on the NO-GO head space gage. If the bolt does not close, extract the NO-GO gage to complete the installation process. If done correctly, the barrel should resist approximately 100 lb<sub>f</sub>-ft (135 Nm) of torque without loosening.
15. If the bolt closes with the NO-GO gage in the chamber, deliver the rifle to a qualified gunsmith for assistance.

Without Recoil Lug

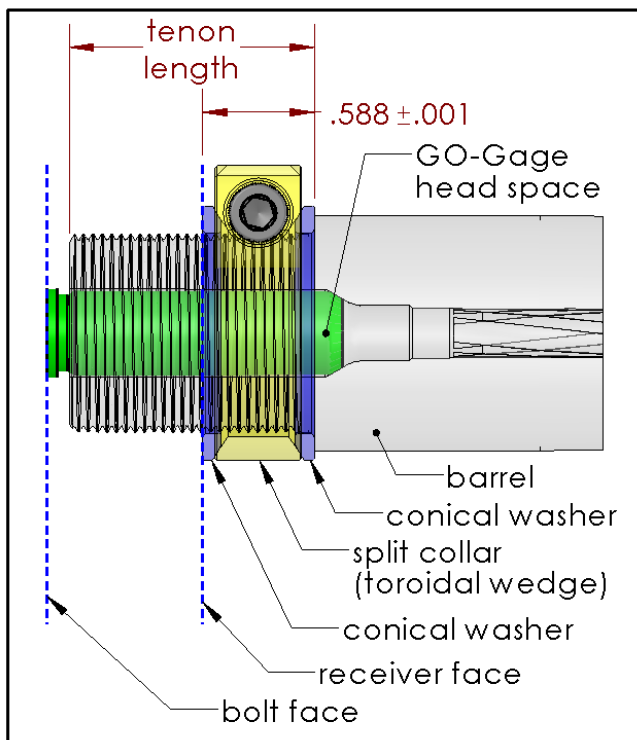

With Recoil Lug

